

Frost Fighter[®] 2300 Uni-Clip Instructions

Uni-Clip Part No. 2710
Master Kit Part No 2700

www.frostfighter.com

The Frost Fighter Uni-Clip Kit is used to replace lost or broken automotive rear window defroster tab/clips. These tabs are typically bonded directly to the defroster grid when they separate from defrosters they can be lost or damaged. The Uni-Clip kit includes replacement

Clips compatible with most makes and models. Some bending may be necessary.

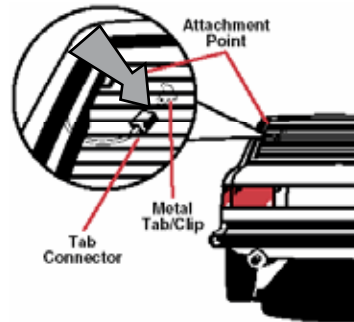

Locate tab connector along edge of rear window

Turn defroster off. Locate the tab connector along rear window edge. The Uni-Clip Kit replaces lost or damaged metal tab/clips. One connector uses a plastic housing with a built-in lock. If the connector is damaged replace with the Frost Fighter Uni-Con connector kit.

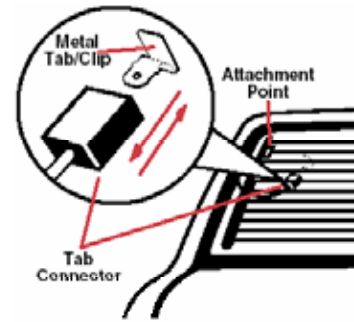

Test fit the replacement Uni-Clip in connector

The Uni-Clip works with both self-locking and metal connector types. Gently push the replacement Uni-Clip into the connector. The tab must fit snugly in the connector. Use pliers to gently tighten metal connectors onto the uni-clip if loose. Remove the tab/clip from the connector.

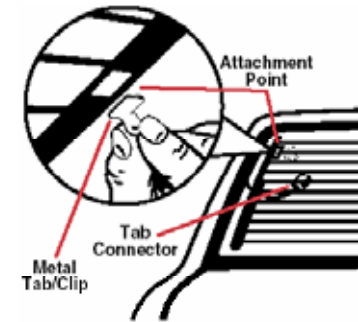

Check position of Uni-Clip and prepare bonding site

Locate the Uni-Clip position on the main side defroster bar. There will likely be part of the old tab or damaged pad area on the defroster. Lightly sand the base of the metal tab and the attachment point where the clip is to be reattached to the defroster tab. **DO NOT OVER SAND THE DEFROSTER GRID.**

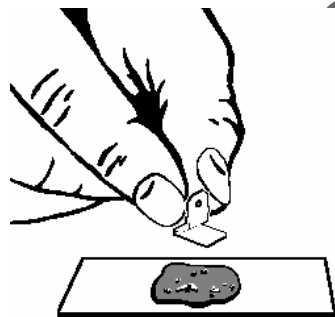

Apply Frost Fighter silver epoxy to bottom of tab

Coat bottom of the new metal tab/clip with the Frost Fighter adhesive by pressing the clip into the adhesive. Carefully check the tab/clip is oriented correctly when placing it back on the defroster. Bonding should be made directly to the main side bar. **SEE TAB REPAIR KIT FOR ADHESIVE INSTRUCTIONS.**

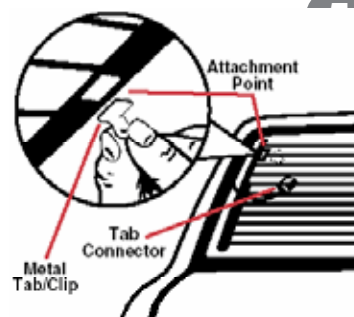

Press metal tab onto defroster side bar

Press the coated metal tab/clip back onto the attachment point, rocking it gently to make a good connection with the grid. Cure for three hours before reattaching the tab connector. Cure at temperatures above 75°F (24°C). Heat cure in 10 minutes at 150-200°F (66-93°C) using a heat gun or hair dryer. **Allow to cure 10 minutes before heating.**

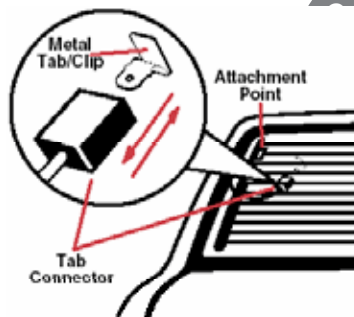

Reattach power tab and defroster

Once the silver epoxy has cured, carefully reattach tab connector to the metal tab. The defroster grid is now ready for testing. **When testing be sure to place your hand on the repair to see if the area is heating up.** If the repair gets hot turn off the defroster and allow the adhesive to cure. The better the cure the better the electrical conductivity.

WARNING:

Warranty and Disclaimer:

Since the Seller cannot control the manner or use of its products after their sale, Seller will not be responsible for any consequential or indirect damages. There are no express warranties which extend beyond the description on the face hereof. Seller disclaims any implied warranties of merchantability or fitness for any particular purpose. The Seller will, at its option, either replace the products sold or refund the purchase. No warranties will apply if the products are in any way altered or modified after delivery by Seller.

Frost Fighter™ is a trademark of
Planned Products
© 1998-2004 Planned Products
MADE AND PRINTED IN USA

Troubleshooting Tips
www.frostfighter.com