

Frost Fighter® Clear View 2620 Front Wiper Heater Kits

Professional rear window defroster repair kits and glass heating systems

www.frostfighter.com



Developed for extreme winter driving conditions Clear View Truck Wiper Heaters fit into the wiper parking area at the bottom of truck windshields eliminating wiper freezing and sticking.

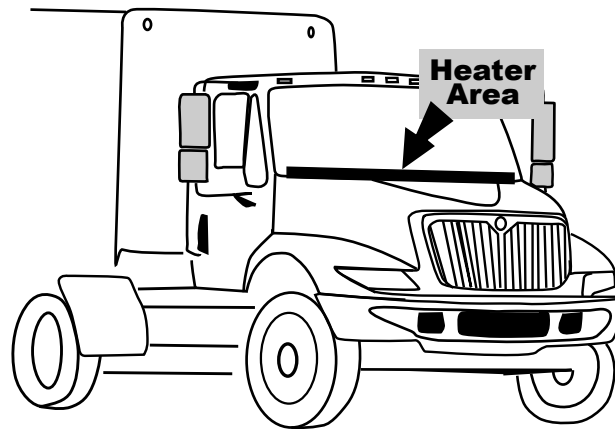

The alternative to pricey heated glass windows the Clear View Front Wiper Heater is easy to install and can be quickly replaced in the field by the vehicle owner if needed.

The heater is very similar to the defroster in the rear window of most cars. Clear View heating elements come on self adhesive pre-spaced rolls that are trimmed to size for easy and accurate installation. The elements bond directly to the glass and are color matched to a factory look with an unobstructed view. The heating elements are connected electrically using kits side bus bars which include mounting tape, brass bus bars and black cover strip.

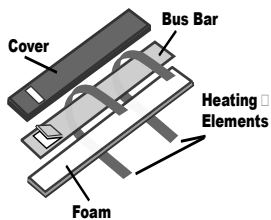
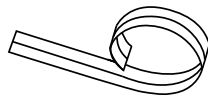

Available in two models the 2620 Kit is delivered complete with all the parts needed to install and wire the kit including a wire harness, fuses, bus bars, covers and an LED illuminated automatic timing switch which turns the defroster off after several minutes of operation just like a factory installation. The 2625 Kit includes the heating elements and side bus bars only. Each kit comes with easy to follow fully illustrated instructions.

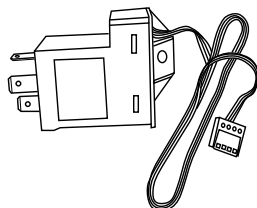

Technical

Voltage	12 VDC
Current.....	5 -7 Amps
Connectors.....	.250 Faston Male Tabs
Wire	14 AWG Black
On Timer	11 Minutes
Grid Layout	Series / Parallel
Elements	Three elements are used
Grid Size	3.75 tall x 80 inch max
Heating Element ..	Copper 1/16 inch wide
Element Spacing ..	1.25 inches
Minimum Width	55 inches
Maximum Width	80 inches
Material Compatible	Glass or plastic*

Modification and Limitations

Clear View kits can be modified to fit many applications but the number of elements and bus bar layout MUST be maintained. Clear View Front Glass Truck Wiper Heaters can only be used on vehicles with full front windows at this time

Plastic requires special installation. Installers should fully test the installation before ordering in quantity.

Kits and Pricing

2620 Clear View Front Wiper Heater Complete Kit

Includes 80 inch three line heating elements, mounting tape, side bus bars, covers, LED illuminated timing switch and relay, wire harness, fuses, bus bars, circuit taping connectors, sand paper, adhesion promoter, mounting hardware and instructions.

Complete Kit - \$58.95

2625 Clear View Front Wiper Heater Stick Kit

Includes the heating grid and mounting bus bars only. This includes 80 inch heating elements, mounting tape, side bus bars, adhesion promoter, cover and instructions.

Stick Kit - \$35.95

All Clear View Wiper Kits are individually packaged unless bulk packaging is requested.

Planned Products LLC
5560 Boulder Hills
Longmont, CO 80503 USA
303.682.0274 Tel
303.682.0678 Fax

planned@boulder.net
www.frostfighter.com

Frost Fighter® Clear View 2620 Front Wiper Heater

Professional rear window defroster repair kits and glass heating systems

www.frostfighter.com



Installation Instructions for the 2620 and 2625 Front Wiper Heater Kits

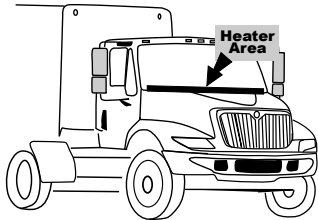

Clear View Defrosters are quality products, designed and manufactured to the highest standards. In order to assure proper installation and obtain maximum performance, care must be taken to follow these installation instructions.

Failure to do this will result in a defective installation. For best results the glass or plastic surface needs to be clean and the defroster grid MUST be applied at temperatures above 60° F (16° C) degrees.

Installing the kit

The heating elements come on pre-spaced rolls which you cut to length for a custom fit. After cleaning the glass and preparing the bus bars these heating elements are applied to the glass, bus bars installed and the heater connected electrically. I installing on PLASTIC please see the Plastic Installation Guide.

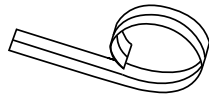

Step 1 - Cleaning

Failure to clean the glass on the window and the brass on the bus bars will cause the units to fail!

1. Wear latex gloves to avoid surface contamination through touching.
2. Sand the brass bus bars using a light grit sand paper on both sides of the bars. Clean them with Isopropyl Alcohol 70% solution (available at almost any pharmacy) using clean paper towels. Make sure the bars are reasonably flat when finished.
3. Clean all glass surfaces with Isopropyl Alcohol 70% solution as follows. Apply the Isopropyl to a clean paper towel then wipe down the surface completely. Dry the surface using a DRY paper towel. **Repeat.** Make sure the glass is wiped dry as the final step.
4. Using the GAP-1 Glass Primer and Adhesion Promoter (included this in each kit) wipe the glass surface completely.
5. Then wipe the brass bus bars using the GAP-1.

Heating Element Layout

Applying the heating elements and side bus bars should follow this pattern. Note the integrated faston tabs face DOWN and the gaps between each section of the bus bar.

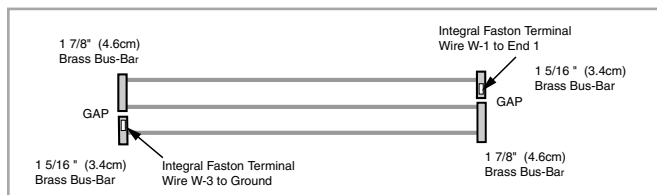

Figure 1. Grid layout and bus bar placement

Step 2 - Applying Heating Elements

The heating elements and side bus bars are easy to apply if you follow these steps. Note this is the LEFT installation which is has a different bus bar layout than the RIGHT.



1

1. Pull away one of the two pieces of release paper with the brown sticky adhesive of the heating element facing OUT. Position the paper and elements on the glass, rub down applying pressure to each element by running a finger or thumb along the element while the backing paper is in place to insure a good bonding contact with the glass.

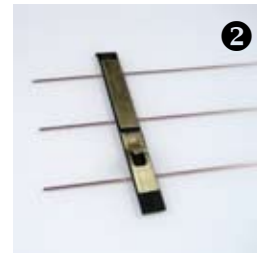

2

2. When all elements are placed and the paper removed apply the double stick tape OVER the copper heating elements **allowing at least one inch of overlap.** Place the bus bars on the tape. Be sure to carefully note the gaps and direction of the tabs when placing these bars. See Fig 1.

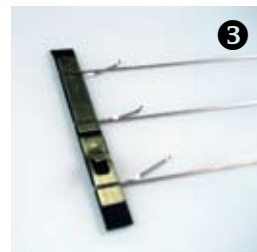

3

3. Bring each element over the bus bar. Make sure the elements DO NOT become twisted. There MUST be a metal to metal contact between the bus bar and the heating elements. Do not pull tight.



4

4. Apply the black plastic cover. Burnish this cover in place using a good deal of pressure with fingers or a small roller. This step is critical



5

5. Snip away the remaining heating element carefully to avoid damaging the heater.

Once the heating elements have been installed its time to move on the electrical installation.

The system runs off 12 volts and can be wired directly using the vehicle existing wiring and a high amperage (20 amps +) on/off lighted switch.

This concludes the installation of the 2525 kit. The 2620 kit includes The full wiring harness and timing switch covered on the following pages.



Electrical Connection - 2620 Complete Kit Only

Clear View 2620 kits come complete with all the wire and connectors needed to install the defroster. All wires are labeled for easy identification. Layout each wire and match the "W" number on the wire with the description.

2620 Wires Components and Marking

No.	Connection	Terminals End 1	End 2	Length
W-1	RWD* to switch	Faston + Clear Cover	Faston + Black Cover	20 Feet (7.6 m)
W-2	Switch to ground	Faston + Clear Cover	Spade Terminal	19 in (48 cm)
W-3	RWD to ground	Faston + Black Cover	Spade Terminal	42 in (107 cm)
W-4	Switch to fuse tap	Faston + Clear Cover	Bare, Not Striped	30 in (76 cm)
W-5	Fuse to power tap	Faston + Blue Tab	Bare, Not Striped	14 in (35.5 cm)
W-6	Ribbon cable from control module to switch (H)	Attached/control mod.	Plug	38 in (96 cm)

* RWD is Rear Window Defroster.



2620 Complete Front Wiper Heater Kit

2620 Wiring Diagram

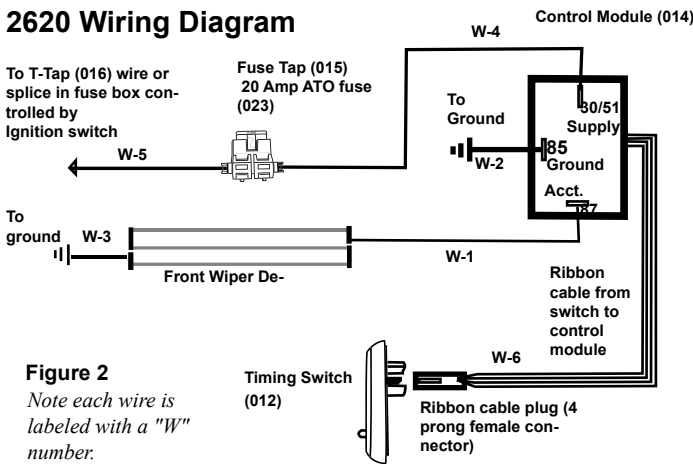

Figure 2
Note each wire is labeled with a "W" number.

STEP 3 - Wire control module

Start the installation by wiring the Control Module (Fig. 3). The module has three terminals each with an identifying number stamped in the plastic near their base. The legend for these numbers is located on the side of the module.

1. Attach wire W-1 (20 feet) to module terminal marked ACC 87 using the faston with the clear cover.
2. Attach wire W-2 to module terminal marked Ground 85 using the faston with clear cover.
3. Attach wire W-4 to module terminal marked Supply +12V 30/51 using the faston with clear cover.

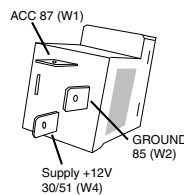

Figure 3
Control Module connector labeling.

4. Attach the spade terminal of wire W-2 to electrical ground in an area behind the dash using one of the kits self-tapping screws if needed.

Warning: Use care if removing connectors from module as this can pull the module apart.

STEP 4 - Mounting control module & switch

Once all the wires are attached to the Control Module secure it behind the dash using wire ties, electrical tape or a self-taping screw. **There are two ways to mount the timing switch.**

Switch Plate Mount

1. Mount the dash switch plate (Fig. 4) in a convenient location with easy access to defroster on/off switch using the self tapping screws

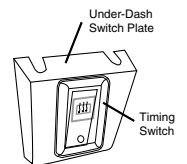

Figure 4
Uses the Dash Switch Plate to mount the touch switch, or drill a 1/2 in hole for an in-dash installation.

2. Run W-6 (Ribbon Cable) through the back of the switch plate and insert the four prong connector into the timing switch, peel away the release film and adhere to plate with the red LED pointing down (Fig. 4).

In Dash Mount

1. If an in-dash installation is preferred drill 1/2 in (1.27 cm) hole in an appropriate area on the dash, run the ribbon cable through hole, connect the ribbon cable, remove the release film and press the switch into place.



STEP 5 - Wire fuse and tap vehicle power

Taping into the vehicles power is a critical step in the installation process. There are two ways to go about taping into vehicle power, using the **wire tap** or **splicing**.

Wire Tap

1. Near the fuse box locate a wire that is about the size of the W-5 wire supplied (14 awg) and is activated when the ignition switch is turned on.
2. Place the wire in the open channel of the Wire Tap (016) supplied, fold the tap body and crimp with pliers. (See Fig. 5 and 6)
3. Slide wire W-5 End 1 (blue terminal) onto the wire tap and secure any loose wire with a wire tie. (Fig. 7)

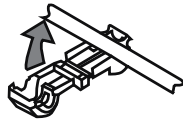

Figure 5
Tap into power wire controlled by ignition.

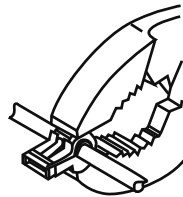

Figure 6
Fold and crimp

Splice

1. Cut off the connector (End 1) of wire W-5 and strip away insulation. Attach the end of wire W-5 to a fuse position or splice into wire which is activated when the ignition switch is turned on.

WARNING: In all cases the fuse and wire used must be adequate to handle 20 amps plus the amperage required by the other units on the same circuit.

Do not use Wire Taps on wire under 16 awg, over 14 awg or on solid wire.

Once wire W-5 has been connected to the vehicles power connect wire W-4 with W-5 using the Fuse Tap (015).

2. Locate the free ends of W-5 and W-4. Check wire lengths and trim to a comfortable length. **Do not strip back insulation.**

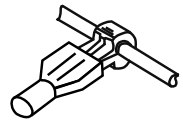

Figure 7
Insert W-5 in Wire Tap

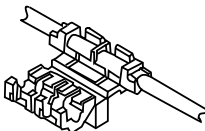

Figure 8
Connecting both wires

3. Insert the free end of W-4 into the Fuse Tap making sure to seat the wire through the tap so that it presses against the center stop in the Tap. (Fig. 8).

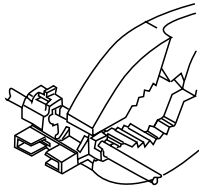

Figure 9
Fold the fuse tap and crimp.

4. Repeat for wire W-5 End 2. Using pliers, fold the connector body and crimp. (Fig. 9)

5. Insert 20 amp ATO fuse supplied and seat it firmly in the fuse tap. It can take some pressure to seat. (Fig. 10)

WARNING: In all cases the ATO 20 Amp fuse and fuse tap **MUST** be used.

Vehicle power has been taped and now runs to the Control Module so it is time to run the wire (W-1) to the grid.

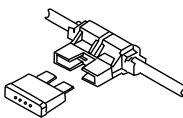

Figure 10
Insert and seat fuse.











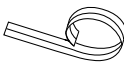

STEP 6 - Connect to heating grid

1. Connect wire W1 to one of the integral tabs on the bus bar. If wire W-1 is too long it can be shortened. Use the extra faston terminal (021) supplied in your kit to attach in place of the one removed. Simply cut off attached faston and crimp on the new faston. You may need a crimp tool to do this properly.
2. Next attach wire W-3 (ground) to the other integral bus bar faston. Wire W-3 can be grounded in the trunk area by drilling a hole in the rear deck or it can be grounded to the rear window frame if it is metallic and grounds to the chassis.
3. Wire W-3 can be shortened and a forked terminal (022) can be crimped to permit attachment to the window molding or grounding area inside the trunk.

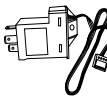
Parts List - 2620 Front Wiper Heater

Take a moment to unpack and familiarize yourself with the various components of the Clear View Kit. The part's item number is referenced in the instructions.

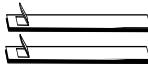
Items not shown: Two wire sets (see list under electrical connection) and ADHESION PROMOTER.

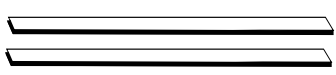
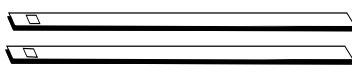
011		1 Roll 3 element copper defroster grid	021		1 Female faston connector
012		1 Timing switch	022		1 Spade Terminal
013		1 Under dash switch mounting plate	023		1 ATO 20 Amp Fuse
014		1 Control module and ribbon cable	024		4 Screws, self-tapping
015		1 Fuse Tap	025		2 Abrasive (sand paper) squares
016		1 T-Tap			
017		2 Brass bus bars, w/ integral tab, 1 5/16 in.			
018		2 Brass bus bars without terminals, 1 7/8 in.			
019		2 Foam mounting strips, adhesive coated both sides, 4 in.			
020		2 Slotted black plastic bus-bar covers with adhesive liner 3 3/4 in.			